



## Orange County Purchasing Department

714 Polk Street Orange, TX 77630  
Phone 409-882-7903 Fax 409-670-4170

---

### NOTICE TO PROPOSERS

Orange County Commissioners' Court will accept sealed competitive proposals at the Orange County Purchasing Agent's Office located at 714 Polk Street, Orange, Texas until 2:00 p.m., CST, Tuesday, May 18, 2023, on the following requirements:

**PROPOSAL NAME:** RAYMOND GOULD COMMUNITY CENTER WALKING TRACK PROJECT 385 CLAIBORNE STREET, VIDOR, TEXAS 77662

**PROPOSAL NO:** RFP-23006

**DUE DATE/TIME:** 2:00 PM, CST, June 08, 2023

**MAIL OR DELIVER TO:** Orange County Purchasing Department  
714 Polk Street  
Orange, TX 77630

Proposal instructions and specifications are available at [www.co.orange.tx.us](http://www.co.orange.tx.us) or the office of the Orange County Purchasing Agent located at 714 Polk Street, Orange, Texas, 77630. Phone 409-882-7903.

Proposals will be publicly opened and only the firm name will be read aloud at the location, time and date above. Proposals shall be opened in a manner that avoids disclosure of the contents to competing offerors and maintains the confidentiality of the proposals during negotiations. Proposals will be open for the public after the award of the contract, except for trade secrets and confidential information. Proposals received after the advertised proposal time will not be accepted and will be returned unopened.

The County shall require the proposer to furnish a proposal bond in the amount of five percent (5%) of the total contract cost if the proposed cost is over \$25,000.00. The proposal bond must be executed with a surety company authorized to do business in the State of Texas

Orange County reserves the right to award this proposal by unit or by lump sum to the most qualified responsible offeror and to increase or decrease quantities as it deems necessary. Orange County also reserves the right to waive any or all formalities and/or technicalities or to reject any or all proposals if in the best interest of the County.

Orange County hereby notifies all offerors that it will affirmatively assure that minority enterprises are afforded full opportunity to submit proposals in response to this RFP, and that they will not be discriminated against on the grounds of race, color or national origin in consideration for an award.

All interested firms are invited to submit a proposal in accordance with the terms and conditions stated in this proposal.

**Proposal Submission:**

**PROPOSAL NAME:** RAYMOND GOULD COMMUNITY CENTER WALKING TRACK PROJECT, 385 CLAIBORNE STREET, VIDOR, TEXAS 77662  
**PROPOSAL NO:** RFP-23006  
**DUE DATE/TIME:** 2:00 PM, CST, June 08, 2023  
**MAIL OR DELIVER TO:** Orange County Purchasing Department  
714 Polk Street  
Orange, TX 77630

Proposals will be accepted at the above address until the time and date specified herein, and immediately after will be publicly opened. All proposals shall be sealed in an envelope and **plainly marked with the Proposal Name, Proposal Number, Due Date, and the Proposer's Name and Address. Late Proposals will not be accepted and will be returned unopened to the proposer.** Offerors shall forward **an original and five (5) copies of their proposal to the address shown above.** All proposals submitted in response to this invitation shall become the property of Orange County and will be a matter of public record available for review.

Questions and/or clarification concerning this RFP must be submitted in writing to Michelle Carroll, Orange County Purchasing Agent [mcarroll@co.orange.tx.us](mailto:mcarroll@co.orange.tx.us) or 714 Polk Street, Orange, Texas, 77630. Deadline for submission of questions and/or clarification is Thursday, June 08, 2023 at 2:00 PM, CST. Request received after the deadline will be not be responded to due to the time constraints of this Proposal process.

**PROPOSER MUST MONITOR THE ORANGE COUNTY PURCHASING WEBSITE AT [www.co.orange.tx.us](http://www.co.orange.tx.us) TO SEE IF ADDENDA OR ADDITIONAL INSTRUCTIONS HAVE BEEN POSTED. ”**

**PROPOSER IS RESPONSIBLE FOR RETURNING ALL REQUIRED PAGES. ADDITIONALLY, FAILURE TO RETURN ALL REQUIRED FORMS COULD RESULT IN A PROPOSAL BEING DECLARED AS NON-RESPONSIVE.**

## **Instructions to Proposers:**

The County of Orange is soliciting Proposal(s) from Contractors who are interested and qualified to provide the following for the Raymond Gould Community Center, located at 385 Claiborne St., Vidor, Texas 77662.

- 1) Reconstruct the walking track
- 2) Parking blocks
- 3) Underground storm drainage

### **Specifications, Equipment and Materials**

The Contractor is to provide services but not limited to the following areas:

Orange County, Texas is seeking proposals for construction services under Orange County established guidelines and policies to comply with Texas State Laws. The selected provider shall furnish all expertise, labor and resources to provide complete service necessary.

Scope of work and methodology details include:

- Obtaining all necessary state and local permits and approvals prior to work being done.
- Responsible for meeting all federal, state, and local requirements for removal, disposal, and handling of any materials required for the project.
- Preparation of the soil for the walking track.
- Pour 1,270 ft concrete walking track consisting of 4" concrete with 6x6x6 wire mesh. (see exhibit B)
- Place and set 18 parking blocks. (see exhibit C)
- Construct underground storm drainage for a portion of the walking track. (see exhibit D)

### **References /Client Listing**

Contractor shall provide a listing of clients, which are currently or have previously used his/her landscaping/irrigation services. References must include the name, address and phone of contact person. As part of the evaluation process, the County will consider if Contractor has successfully serviced an account similar. All reference checks must show that the successful Contractor is in good standing with their current and previous customers.

### **Evaluation Criteria/Contract Award**

An evaluation committee will examine all offers. Orange County, however, reserves the right to accept such an offer if it is determined to be in the County's best interest to do so.

Orange County may initiate discussions with offerers. Additional information will be accepted during this period from offerers who responded to the original request. Offerers may NOT initiate discussions. It is the intent of the County to award to one contractor who submitted the best evaluated response taking into consideration the relative importance of price and other factors set forth in the RFP.

Award of the Contract shall be made to the responsible offerer whose offer is determined to be the best evaluated offer resulting from negotiations, taking into consideration, proposed landscaping specifications and qualities of the proposed plants which best meets the needs of

Orange County. Orange County may use references to make judgments directly affecting the award of this Contract.

**EVALUATION CRITERIA**

The County of Orange will consider the following items as “Selection Criteria” in determining the successful applicant:

- 30% Vendors proposed design
- 20 % Total proposed cost including rates and installation
- 20 % Vendors Qualifications, Experience and License
- 20% Vendors ability to meet requirements/special needs of Orange County
- 10% References

**Negotiations**

Negotiations may be conducted with responsible Contractors(s) who submit Proposals that are reasonably susceptible of being selected. Contractors will be ranked in order of preference and contract negotiations will begin with the top ranked Contractor. Should negotiations with the highest ranked Contractor fail to yield a contract, or if the Contractor is unable to execute said contract, negotiations will be formally ended and then commence with the second highest ranked Contractor, etc. However, the County, may in its sole discretion, award a contract without interviews, based solely on information supplied in the proposal responses.

**Preparation of Proposals**

The proposal shall be legibly printed in ink or typed. If a unit price or extension already entered is to be altered, it shall be crossed out and initialed in ink by the proposer. The Proposal shall be legally signed and shall include the complete address of the proposer. Orange County is exempt from Federal and State Sales Taxes, and such taxes shall not be included in Proposal prices.

**Signatures**

All Proposals, notifications, claims, and statements must be signed by an individual authorized to bind the proposer. The individual signing certifies, under penalty of perjury, that he or she has the legal authorization to b

**Rejection or Withdrawal**

Submission of additional terms, conditions or agreements with the Proposal document are grounds for deeming a Proposal non-responsive and may result in Proposal rejection. Orange County reserves the right to reject any and all Proposals and to waive any informalities and minor irregularities or defects in Proposals. Proposals may be withdrawn in person by a proposer or authorized representative, provided their identity is made known and a receipt is signed for the Proposal, but only if the withdrawal is made prior to the time set for receipt of Proposals. Proposals are an irrevocable offer and may not be withdrawn within 90 days after opening date.

**Award**

Proposal will be awarded to the responsible, responsive proposer(s) who’s Proposal, conforming to the solicitation, will be most advantageous to Orange County – price and other

factors considered. Unless otherwise specified in this RFP, Orange County reserves the right to accept a Proposal in whole or in part, and to award by item or by group, whichever is deemed to be in the best interest of Orange County. Any proposer who is in default to Orange County at the time of submittal of the Proposal shall have that Proposal rejected. Orange County reserves the right to clarify any contractual terms with the concurrence of the Contractor; however, any substantial nonconformity in the offer, as determined by Orange County, shall be deemed non-responsive and the offer rejected. In evaluating Proposals, Orange County shall consider the qualifications of the proposers, and, where applicable, operating costs delivery time, maintenance requirements, and performance data, guarantees of materials and equipment. In addition, Orange County may conduct such investigation, as it deems necessary to assist in the evaluation of a Proposal and to establish the responsibility, qualifications, and financial ability of the proposers to fulfill the contract. Orange County reserves the right to award this contract on the basis of lowest and best Proposal in accordance with the laws of the State of Texas, to waive any formality or irregularity, to make awards to more than one offeror, and/or to reject any or all Proposals. In the event the lowest dollar offeror meeting specifications is not awarded a contract, Offeror may appear before the Commissioners' Court and present evidence concerning Offeror responsibility after officially notifying the Office of the Purchasing Agent of Offeror's intent to appear.

### **Contract**

A response to an RFP is an offer to contract with Orange County based upon the terms, conditions, and specifications contained in the RFP. Proposals do not become contracts unless and until they are executed by Orange County, eliminating a formal signing of a separate contract. For that reason, all of the terms and conditions of the contract are contained in the RFP, unless any of the terms and conditions is modified by an RFP Amendment, a Contract Amendment, or by mutually agreed terms and conditions in the contract documents

### **Fiscal Funding**

A multi-year lease or lease/purchase arrangement (if requested by the Special Requirements/Instructions), or any contract continuing as a result of an extension option, must include fiscal funding out. If, for any reason, funds are not appropriated to continue the lease or contract, said lease or contract shall become null and void. After expiration of the lease, leased equipment shall be removed by the offeror from the using department without penalty of any kind or form to Orange County. All charges and physical activity related to delivery, installation, removal and redelivery shall be the responsibility of the offeror.

### **Addenda and Changes to Proposal Documents**

Each addendum or change issued in relation to this RFP document will be on file in the Office of the Purchasing Agent, and will be posted on the Orange County Purchasing web site [www.orange.tx.us](http://www.orange.tx.us) as soon as possible. It shall be the proposer's responsibility to make inquiry as to change or addenda issued, and to monitor the web site. All such changes or addenda shall become part of the contract and all proposers shall be bound by such addenda.

### **Specifications**

Unless otherwise stated by the proposer, the Proposal will be considered as being in accordance with Orange County's applicable standard specifications, and any special

specifications outlined in the Proposal document. References to a particular trade name, manufacturer's catalogue, or model number are made for descriptive purposes to guide the proposer in interpreting the requirements of Orange County, and should not be construed as excluding Proposals on other types of materials, equipment, and supplies. However, the proposer, if awarded a contract, will be required to furnish the particular item referred to in the specifications or description unless departure or substitution is clearly noted and described in the Proposal. Orange County reserves the right to determine if equipment/ product being Proposal are an acceptable alternate. All goods shall be new and unused unless otherwise so stated in the Proposal. Any unsolicited alternate Proposal, or any changes, insertions, or omissions to the terms and conditions, specifications, or any other requirements of the Proposal, may be considered non-responsive.

**Delivery**

Proposals shall include all charges for delivery, packing, crating, containers, etc. Proposals will be considered as being based on F.O.B. destination/delivered freight included.

**Interpretation of Proposal and/or Contract Documents**

All inquiries shall be made within a reasonable time prior to the date and time fixed for the Proposal opening, in order that a written response in the form of an addendum, if required, can be processed before the Proposals are opened. Inquiries received that are not made in a timely fashion may or may not be considered.

**Currency**

Prices calculated by the proposer shall be stated in U.S. dollars.

**Pricing**

Prices shall be stated in units of quantity specified in the Proposal documents. In case of discrepancy in computing the amount of the Proposal, the unit price shall govern.

**Notice to Proceed/Purchase Order**

The successful proposer may not commence work under this contract until authorized to do so by the Purchasing Agent.

**Certification**

By signing the offer section of the Offer to Contract page, proposer certifies: The submission of the offer did not involve collusion or other anti-competitive practices. The proposer has not given, offered to give, nor intends to give at any time hereafter, any economic opportunity, future employment, gift, loan, gratuity, special discount, trip, favor, or service to any public servant in connection with the submitted offer. The proposer hereby certifies that the individual signing the Proposal is an authorized agent for the proposer and has the authority to bind the proposer to the contract.

**Minority-Women Business Enterprise Participation**

It is the desire of Orange County to increase the participation of Minority (MBE) and women-owned (WBE) businesses in its contracting and procurement programs. While the County does

not have any preference or set aside programs in place, it is committed to a policy of equitable participation for these firms.

**Grant Funding**

Any contract entered into by the County that is to be paid from grant funds shall be limited to payment from the grant funding and the vendor/provider understands that the County has not set aside any County funds for the payment of obligations under a grant contract. If grant funding should become unavailable at any time for the continuation of services paid for by the grant, and further funding cannot be obtained for the contract, then the sole recourse of the provider shall be to terminate any further services under the contract and the contract shall be null and void.

**HIPPA Compliance**

Offeror agrees to comply with the Standards for Privacy of Individually Identifiable Health Information of the Health Insurance Portability and Accountability Act of 1996, PL 104-191 45 CFR Parts 160-164, as amended, and the Texas Medical Records Privacy Act, Texas Health and Safety Code Chapter 181, as amended, collectively referred to as "HIPPA" to the extent that the Offeror uses, disclosed or has access to protected health information as defined by HIPPA. Offeror may be required to enter a Business Associate Agreement pursuant to HIPPA.

**Hold Harmless Agreement**

Contractor, the successful offeror, shall indemnify and hold Orange County harmless from all claims for personal injury, death and/or property damage resulting directly or indirectly from contractor's performance. Contractor shall procure and maintain, with respect to the subject matter of this Proposal, appropriate insurance coverage including, as a minimum, public liability and property damage with adequate limits to cover contractor's liability as may arise directly or indirectly from work performed under terms of this Proposal. Certification of such coverage must be provided to Orange County Purchasing before any work begins.

**Waiver of Subrogation**

Offeror and offeror's insurance carrier waive any and all rights whatsoever with regard to subrogation against Orange County as an indirect party to any suit arising out of personal or property damages resulting from offeror's performance under this agreement.

**Severability**

If any section, subsection, paragraph, sentence, clause, phrase or word of these requirements or the specifications shall be held invalid, such holding shall not affect the remaining portions of these requirements and the specifications and it is hereby declared that such remaining portions would have been included in these requirements and the specifications as though the invalid portion had been omitted.

**Recycled Materials**

Orange County encourages the use of products made of recycled materials and shall give preference in purchasing to products made of recycled materials if the products meet applicable specifications as to quantity and quality. Orange County will be the sole judge in determining product preference application.

### **Scanned or Re-Typed Response**

If in its Proposal response, offeror either electronically scans, re-types, or in some way reproduces the County's published Proposal package, then in event of any conflict between the terms and provisions of the County's published Proposal specifications, or any portion thereof, and the terms and provisions of the Proposal response made by offeror, the County's Proposal specifications **as published** shall control. Furthermore, if an alteration of any kind to the County's published Proposal specifications is only discovered after the contract is executed and is or is not being performed; the contract is subject to immediate cancellation.

### **Electronic Data**

If offeror obtained the Proposal specifications on a disk in or web site order to prepare a response, the Proposal must be submitted in hard copy according to the instructions contained in this Proposal package. If, in its Proposal response, offeror makes any changes whatsoever to the County's published Proposal specifications; the County's Proposal specifications as published shall control. It is preferred that you enter your data on the disk, do a print and then return disk and print out. You must return a hard copy Proposal and return the disk.

### **New Millennium Compliance**

All products and/or services furnished, as part of this contract must be year 2000 compliant. This applies to all computers including hardware and software as well as all other commodities with date sensitive embedded chips.

### **E-Mail Addresses Consent**

Vendor affirmatively consents to the disclosure of its e-mail addresses that are provided to Orange County. This consent is intended to comply with the requirements of the Texas Public Information Act, Tex. Gov't Code Amn. 522.137 as amended, and shall survive termination of this agreement. This consent shall apply to e-mail addresses provided by Vendor, its employees, officers, and agents acting on Vendor's behalf and shall apply to any e-mail address provided in any form for any reason whether related to this Proposal/Proposal or otherwise.

### **Potential Conflicts of Interest**

An outside consultant or contractor is prohibited from submitting a Proposal for services on an Orange County project of which the consultant or contractor was a designer or other previous contributor, or was an affiliate, subsidiary, joint venture or was in any other manner associated by ownership to any party that was a designer or other previous contributor. If such a consultant or contractor submits a prohibited Proposal, that Proposal shall be disqualified on the basis of conflict of interest, no matter when the conflict is discovered by Orange County. A conflict of interest questionnaire is included to be filled out and returned.

### **Governing Law**

This invitation to Proposal is governed by the competitive Proposal requirements of the County Purchasing Act, Texas Local Government Code, §262.021 *et seq.*, as amended. Offerors shall comply with all applicable federal, state and local laws and regulations. Offeror is further advised that these requirements shall be fully governed by the laws of the State of Texas and that Orange County may request and rely on advice, decisions and opinions of the Attorney General of Texas and the County Attorney concerning any portion of these requirements.

### **Access to Records**



In special circumstances, vendor may be required to allow duly authorized representatives of Orange County or the state and federal government access to contacts, books, documents, and records necessary to verify the nature and extent of the cost of services provided by vendor.

### **Governing Forms**

In the event of any conflict between the terms and provisions of these requirements and the specifications, the specifications shall govern. In the event of any conflict of interpretation of any part of this overall document, Orange County's interpretation shall govern.

### **Supplemental Materials**

Offerors are responsible for including all pertinent product data in the returned Proposal package. Literature, brochures, data sheets, specification information, completed forms requested as part of the Proposal package and any other facts which may affect the evaluation and subsequent contract award should be included. Materials such as legal documents and contractual agreements, which the offeror wishes to include as a condition of the Proposal, must also be in the Proposal package. Failure to include all necessary and proper supplemental materials may be cause to reject the entire Proposal.

### **Inspections**

Orange County reserves the right to inspect any item(s) or service location for compliance with specifications and requirements and needs of the using department. If an offeror cannot furnish a sample of a Proposal item, where applicable, for review, or fails to satisfactorily show an ability to perform; the County can reject the Proposal as inadequate.

### **Testing**

Orange County reserves the right to test equipment, supplies, material and goods Proposal for quality, compliance with specifications and ability to meet the needs of the user. Demonstration units must be available for review. Should the goods or services fail to meet requirements and/or be unavailable for evaluation, the Proposal is subject to rejection.

### **Disqualification of Offeror**

Upon signing this Proposal document, an offeror offering to sell supplies, materials, services, or equipment to Orange County certifies that the offeror has not violated the antitrust laws of this state codified in Texas Business and Commerce Code §15.01, et seq., as amended, or the federal antitrust laws, and has not communicated directly or indirectly the Proposal made to any competitor or any other person engaged in such line of business. Any or all Proposals may be rejected if the County believes that collusion exists among the offerors. Proposals in which the prices are obviously unbalanced may be rejected. If multiple Proposals are submitted by an offeror and after the Proposals are opened, one of the Proposals is withdrawn, the result will be that all of the Proposals submitted by that offeror will be withdrawn; however, nothing herein prohibits a vendor from submitting multiple Proposals for different products or services.

### **Assignment**

The successful offeror may not assign, sell or otherwise transfer this contract without written permission of Orange County Commissioners Court.

### **Contract Obligation**

Court must award the contract and the County Judge or other person authorized by the Orange County Commissioners Court must sign the contract before it becomes binding on Orange

County or the offerors. Binding agreements shall remain in effect until all products and/or services covered by this purchase have been satisfactorily delivered and accepted.

### **Title Transfer**

Title and Risk of Loss of goods shall not pass to Orange County until Orange County actually receives and takes possession of the goods at the point or points of delivery.

### **Equivalents of Equal Quality are Acceptable**

Whenever an article or material is defined by describing a proprietary product, or by using the name of a manufacturer, the term "or equivalent" if not inserted, shall be implied. The specified article or material shall be understood as descriptive, not restrictive.

### **Substitutions after Award of the Contract**

After the award of the contract, no substitutions will be made without prior approval from the County Purchasing Agent. Should any items on the contract be discontinued or otherwise become unattainable during the life of the contract, test will be made of substitutes at the discretion of the County Purchasing Agent.

### **General Terms and Conditions of Proposal and Term Contracts**

#### **1. Proposal**

**1.1 Proposals.** All Proposals must be submitted on the Proposal form furnished in this package.

**1.2 Authorized Signatures.** The Proposal must be executed personally by the vendor, duly authorized partner of the partnership, or duly authorized officer of the corporation. If executed by an agent, a power of attorney or other evidence of authority to act on behalf of the vendor shall accompany the Proposal to become a valid Proposal.

**1.3 Late Proposals.** Proposals must be in the office of the Orange County Purchasing Agent before or at the specified time and date Proposals are due. Proposals received after the submission deadline shall be rejected as non-responsive and returned unopened.

**1.4 Withdrawal of Proposals Prior to Proposal Opening.** A Proposal may be withdrawn before the opening date by submitting a written request to the Purchasing Agent. If time allows, the proposer may submit a new Proposal. Proposer assumes full responsibility for submitting a new Proposal before or at the specified time and date Proposals are due. Orange County reserves the right to withdraw a request for Proposals before the opening date.

**1.5 Proposal Amounts.** Proposals shall show net prices, extensions where applicable and net total. In case of conflict between unit price and extension, the unit price will govern. Any ambiguity in the Proposal as a result of omission, error, unintelligible or illegible wording shall be interpreted in the favor of Orange County.

**1.6 Exceptions and/or Substitutions.** All Proposals meeting the intent of the specifications and plans will be considered for award. Vendors taking exception to the specifications and plans, or offering substitutions, shall state these exceptions in the section provided. If Proposal is made on an article other than the one specified, which a proposer considers comparable, the name and grade of said article must be specified in the Proposal and sufficient specifications and descriptive data must accompany same to permit thorough evaluation. The absence of stated exceptions and/or substitutions shall indicate that the vendor has not taken any exceptions to the specifications and shall be responsible to perform in strict accordance with the specifications. As a matter of practice, Orange County rejects exception(s) and /or substitutions as non-responsive but reserves the right to accept any and/or all of the exception(s) and/or substitution(s) deemed to be in the best interest of Orange County.

**1.7 Alternates.** The Invitation for Proposal and/or specifications may expressly allow proposer to submit an alternate Proposal. Presence of such an offer shall not be considered an indication of non-responsiveness.

**1.8 Descriptions.** Unless otherwise specified, any reference to make, manufacturer and/or model used in the Proposal specifications is merely descriptive and not restrictive, and is used only to indicate type, style, or quality of material desired.

**1.9 Proposal Alterations.** Proposals cannot be altered or amended after submission deadline. Any interlineations, alterations, or erasures made before opening time must be initialed by the signer of the Proposal, guaranteeing authenticity.

**1.10 Tax Exempt Status.** Orange County is exempt from federal excise tax and state sales tax. Unless the Proposal form or specifications specifically indicate otherwise, the Proposal price must be net, exclusive of above-mentioned taxes and will be so construed. Therefore, the Proposal price shall not include taxes. ORANGE COUNTY claims exemption from all sales and/or use taxes under Texas Tax Code §151.309, as amended. Texas Limited Sales Tax Exemption Certificates will be furnished upon written request to the Orange County Auditor

**1.11 Quantities.** Quantities indicated are estimated quantities only and are not a commitment to buy. Approximate usage does not constitute an order, but only implies the probable quantity that will be used. Commodities will be ordered on an as-needed basis. Proposer is responsible for accurate final counts.

**1.12 Proposal Award.** Award of contract shall be made to the most responsible, responsive proposer, whose offer is determined to be the best value, taking into consideration the relative importance of price. Orange County reserves the right to be the sole judge as to whether items Proposal will serve the purpose intended. Orange County reserves the right to accept or reject in part or in whole any Proposal submitted, and to waive any technicalities or informalities for the best interest of the County. Orange County reserves the right to award based upon individual line items, sections or total Proposal.

**1.13 Silence of Specifications for Complete Units.** All materials, equipment and/or parts that will become a portion of the completed work, including items not specifically stated herein but, necessary to render the service(s) complete and operational per the specifications, are to be included in the Proposal price. Vendor may be required to furnish evidence that the service, as Proposal, will meet or exceed these requirements.

**1.14 General Proposal Bond/Surety Requirements.** Failure to furnish Proposal bond or bonds will result in Proposal being declared non-responsive. Non-responsive Proposals will not be considered for award.

**1.15 General Insurance Requirements.** Failure to furnish Affidavit of Insurance, if required in these specifications, will result in Proposal being declared non-responsive. Non-responsive Proposals will not be considered for award.

**1.16 Responsiveness.** A responsive Proposal shall substantially conform to the requirements of this Invitation to Proposal and/or specifications contained herein. Proposers who substitute any other terms, conditions, specifications and/or requirements or who qualify their Proposals in such a manner as to nullify or limit their liability to the contracting entity shall have their Proposals deemed non-responsive. Also, Proposals containing any clause that would limit contracting authority shall be considered non-responsive. Examples of nonresponsive Proposals include but shall not be limited to: a) Proposals that fail to conform to required delivery schedules as set forth in the Proposal request; b) Proposals with prices qualified in such a manner that the Proposal price cannot be determined, such as with vague wording that may include "price in effect at the time of delivery," and c) Proposals made contingent upon award of other Proposals currently under consideration.

**1.17 Responsible Standing of Proposer.** To be considered for award, proposer must at least: have the ability to obtain adequate financial resources, be able to comply with required or proposed delivery/ completion schedule, have a satisfactory record of performance; have a satisfactory record of integrity and ethics, and be otherwise qualified and eligible to receive award.

**1.18 Proprietary Data.** Proposer may, by written request, indicate as confidential any portion(s) of a Proposal that contain proprietary information, including manufacturing and/or design processes exclusive to the vendor. Orange County will protect from public disclosure such portions of a Proposal, unless directed otherwise by legal authority, including existing Open Records Acts.

## **2. Performance**

**2.1 Design, Strength, and Quality.** Design, strength, and quality of materials and workmanship must conform to the highest standards of manufacturing and engineering practices. The apparent silence of specifications and/or plans as to any detailed description concerning any point shall be regarded as meaning that only the best commercial practices are to prevail. All interpretations of these specifications and/or plans shall be made on the basis of this statement.

**2.2 Age and Manufacture.** All tangible goods being proposed must be new and unused, unless otherwise specified, in first-class condition, of current manufacture, and furnished ready to use. All items not specifically mentioned that are required for a complete unit shall be furnished.

**2.3 Delivery Schedule.** Delivery time may be an important consideration in the evaluation of best value. The maximum number of days necessary for delivery ARO shall be stated in the space, if provided, on the Proposal form.

**2.4 Delivery Charges.** All delivery and freight charges, F.O.B. destination shown on Orange County purchase order, as necessary to perform contract are to be included in the Proposal price.

**2.5 Installation Charges.** All charges for assembly, installation and set-up shall be included in the Proposal price. Unless otherwise stated, assembly, installation and set-up will be required.

**2.6 Operating Instructions and Training.** Clear and concise operating instructions and descriptive literature will be provided in English, if requested. On-site detailed training in the safe and efficient use and general maintenance of item(s) purchased shall be provided as needed at the request of Orange County. Instructions and training shall be at no additional cost to the County.

**2.7 Compliance with Federal, State, County, and Local Laws.** Proposals must comply with all federal, state, county and local laws, including, but not limited to, all applicable standard safety, emission, and noise control requirements. Any vehicles or equipment shall contain all standard safety, emission, and noise control requirements required for the types and sizes of equipment at the time of their manufacture. The contractor agrees, during the performance of work or service, to comply with all applicable codes and ordinances of Orange County or the State of Texas as they may apply, as these laws may now read, or as they may hereafter be changed or amended.

**2.8 OSHA.** The proposer will certify all equipment complies with all regulations and conditions stipulated under the Williams-Steiger Occupational Safety and Health Act of 1971, as amended. The successful proposer will further certify that all items furnished under this project will conform and comply with federal and State of Texas OSHA standards. The successful proposer will agree to indemnify and hold harmless Orange County for any and all damages that may be assessed against the County.

**2.9 Patents and Copyrights.** The successful vendor agrees to protect the County from claims involving infringements of patents and/or copyrights.

**2.10 Samples, Demonstrations and Testing.** At Orange County's request and direction, proposer shall provide product samples and/or testing of items Proposal to ensure compliance with specifications. Samples, demonstrations and/or testing may be requested at any point prior to or following Proposal award. Samples, demonstrations and/or testing may be requested upon delivery and/or any point during the term of resulting contract. All samples (including return thereof), demonstrations, and/or testing shall be at the expense of the proposer/vendor.

**2.11 Acceptability.** All articles enumerated in the Proposal shall be subject to inspection by an officer designated for that purpose by Orange County. If found inferior to the quality called for, or not equal in value to the specifications, deficient in workmanship or otherwise, this fact shall be certified to the Purchasing Agent, who shall have the right to reject the whole or any part of the same. Items and/or work determined to be contrary to specifications must be replaced at the vendor's expense. Inferior items not retrieved by the vendor within thirty (30) calendar days or an otherwise agreed upon time, shall become the property of the County. If disposal of such items warrants an expense, an amount equal to the disposal expense will be deducted from amounts payable to the vendor.

**2.12 Maintenance.** Maintenance required for equipment Proposal should be available in Orange County by a manufacturer authorized maintenance facility. Cost for this service shall be shown on the Proposal sheet as requested or on a separate sheet, as required. If Orange County opts to include maintenance, it shall be so stated in the purchase order and said cost will be included. Service will commence only upon expiration of applicable warranties and should be priced accordingly.

**2.13 Material Safety Data Sheets.** Under the "Hazardous Communications Act," common known as the "Texas Right to Know Act," a proposer must provide the user department, with each delivery, material safety data sheets which are applicable to hazardous substances defined in the Act. Failure of the proposer to furnish this documentation will be cause to reject any Proposal applying thereto.

**2.14 Evaluation.** Evaluation shall be used as a determinant as to which services are the most efficient and/or most economical for the County. It shall be based on all factors having a bearing on price and performance of the items in the user environment. All Proposals are subject to tabulation by the Orange County Purchasing Department and recommendation to Orange County Commissioners' Court. Compliance with all Proposal requirements and needs of the using department are considered in evaluating Proposals. Pricing is not the only criteria for making a recommendation. The Orange County Purchasing Department reserves the right to contact any proposer, at any time, to clarify, verify or requirement information with regard to this Proposal.

### **3. Purchase Orders and Payment**

**3.1 Purchase Orders.** A purchase order(s) shall be generated by the Orange County Purchasing Agent to the successful vendor. The purchase order number must appear on all itemized invoices and packing slips. The County will not be held responsible for any work orders placed and/or performed without a valid current purchase order number. Payment will be made for all services rendered and accepted by the contract administrator for whom a valid invoice has been received.

**3.2 Invoices.** All invoices shall reference the Purchase Order number. Invoices shall reference a detailed description for each item invoiced. If an item purchased and itemized on the invoice does not correspond to an item in any of the categories awarded to the vendor, invoice shall reference the item as "N/C" to indicate that it is a non-contract item. This requirement is to assist the County in verifying contract pricing on all invoices. Payment will be made under terms of net thirty (30) days unless otherwise agreed upon by seller and the purchasing department.

**3.3 Prompt Payment.** In accordance with the State of Texas Prompt Payment Act, Article 601f V.T.C.S., payment will be made after receive and acceptance by the County of the merchandise ordered and of a valid invoice. Successful proposer(s) is required to pay subcontractors within ten (10) days after the successful proposer receives payment from the County.

**3.4 Funding.** Orange County is operated and funded on an October 1 to September 30 basis; accordingly, the County reserves the right to terminate, without liability to the County, any contract for which funding is not available.

#### **4. Contract**

**4.1 Contract Definition.** The General Conditions of Proposal and Terms of Contract, Specifications, Plans, Proposal Forms, Addenda, and any other documents made a part of this Proposal shall constitute the complete Proposal. This Proposal, when duly accepted by Orange County, shall constitute a contract equally binding between the successful proposer and Orange County.

**4.2 Contract Agreement.** Once a contract is awarded, the unit prices offered by the successful proposer shall remain firm for the term of the contract. Contract shall commence on date of award.

**4.3 Change Order.** No different or additional terms will become part of this contract with the exception of a change order. No oral statement of any person shall modify or otherwise change, or affect the terms, conditions or specifications stated in the resulting contract. All change orders to the contract will be made in writing and at the discretion and approval of Orange County. No change order will be binding unless signed by an authorized representative of the County and the vendor.

**4.4 Termination.** Orange County reserves the right to terminate the contract for default if the proposer breached any of the terms therein, including warranties of proposer or if the proposer becomes insolvent or commits acts of bankruptcy. Such right of termination is in addition to and not in lieu of any other remedies, which Orange County may have in law or equity. Default may be construed as, but not limited to, failure to deliver the proper goods and/or service within the proper amount of time, and/or to properly perform any and all services required to Orange County's satisfaction and/or to meet all other obligations and requirements. Contracts may be terminated without cause upon thirty- (30) days' written notice to either party unless otherwise specified. Orange County reserves the right to award canceled contract to the next lowest proposer. Proposer, in submitting this Proposal, agrees that Orange County shall not be liable to prosecution for damages in the event that the County declares the proposer in default.

**4.5 Conflict of Interest.** Employees of the County are not permitted to maintain financial interest in, or receive payment, directly or indirectly, borrow from, lend to, invest in, or engage in any substantial financial transaction with any individual, organization, supplier, or subcontractor who does business with the County without disclosure. When conflict of interest is discovered, it shall be grounds for termination of contract.

**4.6 Injuries or Damages Resulting from Negligence.** Successful vendor shall defend, indemnify and save harmless Orange County and all its officers, agents and employees from all suits, actions, or other claims of any character, name and description brought for or on account of any injuries or damages received or sustained by any person, persons, or property on account of any negligent act or fault of the successful vendor, or of any agent, employee, subcontractor or supplier in the execution of, or performance under, any contract which may result from Proposal award. Successful vendor shall pay any judgment with cost, which may be obtained, against Orange County growing out of such injury or damages.

**4.7 Interest by Public Officials.** No public official shall have interest in this contract, in accordance with Texas Local Government Code.

**4.8 Warranty.** Offerors shall furnish all data pertinent to warranties or guarantees, which may apply to items in the Proposal. Offerors may not limit or exclude any implied warranties. Offeror warrants that product sold to the County shall conform to the standards established by the U.S. Department of Labor under the Occupational Safety and Health Act of 1970. In the event product does not conform to OSHA Standards, where applicable, Orange County may return the product for correction or replacement at the offeror's expense. If offeror fails to make the appropriate correction within a reasonable time, Orange County may correct at the offeror's expense.

**4.9 Uniform Commercial Code.** The successful vendor and Orange County agree that both parties have all rights, duties, and remedies available as stated in the Uniform Commercial Code.

**4.10 Venue.** This agreement will be governed and construed according to the laws of the State of Texas. This agreement is performable in the County of Orange, Texas.

**4.11 Sale, Assignment, or Transfer of Contract.** The successful vendor shall not sell, assign, transfer or convey this contract, in whole or in part, without the prior written consent of Orange County.

**4.12 Silence of Specifications.** The apparent silence of these specifications as to any detailed description concerning any point shall be regarded as meaning that only the best commercial practices are to prevail. All interpretations of these specifications shall be made on the basis of this state

#### **Method of Payment**

Invoices shall be sent directly to the:

**COUNTY AUDITOR'S OFFICE  
123 S. 6<sup>th</sup> Street  
ORANGE, TX 77630**

Payments are processed after the Auditor's Office has been notified that the items have been received in good conditions and no unauthorized substitutions have been made. Invoices must detail the items delivered and must reference the Orange County Purchase Order Number for speed in processing. The County will only receive delivery for goods as required, and the County shall only be billed for goods ordered and delivered.

#### **Insurance Requirements**

**Purchase Order or Contract will NOT be released until vendor provides all required documents to Orange County Purchasing.**

Failure to furnish Affidavit of Insurance, if required in these specifications, will result in Proposal being declared non-responsive. Non-responsive Proposals will not be considered for award. Before commencing work, the successful proposer shall be required, at his own expense, to furnish the Orange County Purchasing Agent within ten (10) days of notification of award with certified copies of all insurance policies showing the following insurance coverage to be in force throughout the term of the contract. No Purchase Order will be released until all required documents are provided to Orange County Purchasing.

- (a) Commercial General Liability insurance at minimum combined single limits of \$1,000,000.00 per-occurrence and \$1,000,000.00 general aggregate for bodily injury and property damage, which coverage shall include products/completed operations, (1,000,000.00 products/completed operations aggregate). Coverage for products/completed operations must be maintained for a least two- (2) years after the construction work is completed. Coverage must be written on an occurrence form Contractual liability must be maintained with respect to the contractor's obligations contained in the contract. The general aggregate limit must be at least two (2) times the per-occurrence limit. A per-project aggregate endorsement must be included.

- (b) Workers Compensation insurance at statutory limits, including employer's liability coverage at minimum limits of \$500,000.00 per occurrence each accident/\$500,000.00 by disease per-occurrence/\$500,000.00 by disease aggregate.
- (c) Commercial Automobile Liability insurance at minimum combined single limits of \$1,000,000.00 per-occurrence for bodily injury and property damage, including owned, non-owned and hired vehicle coverage.

The required limits may be satisfied by any combination of primary, excess or umbrella liability insurance's, provided the primary policy complies with the above requirements and the excess umbrella is following form. The successful proposer may maintain reasonable and customary deductibles, subject to approval by Orange County.

A comprehensive general liability insurance form may be used in lieu of a commercial general liability insurance form. In this event, coverage must be written on an occurrence basis, at limits of \$1,000,000.00 per-occurrence, combined single limit; and coverage must include a broad form comprehensive general liability endorsement, coverage for products/completed operations, and broad form contractual liability covering the obligations included in the contract.

With reference to the foregoing insurance requirement, the successful proposer shall specifically endorse applicable insurance policies as follows:

1. Orange County shall be named as an additional insured with respect to general liability.
2. All liability policies shall contain cross liability and severability of interest clauses
3. A waiver of subrogation in favor of Orange County shall be contained in the workers compensation, general liability, and automobile liability coverage.
4. All insurance policies shall be endorsed to require the insurer to immediately Orange County of any material change in the insurance coverage.
5. All insurance policies shall be endorsed to the effect that Orange County will receive at least sixty- (60) day's notice prior to cancellation, non-renewal or termination of the insurance.

All insurance shall be purchased from an insurance company that meets the following requirements:

1. A financial rating of A: VII or better as assigned by the BEST Rating Company.
2. Licensed and admitted to do business in the State of Texas

All insurance must be written on forms filed with and approved by the Texas State Board of Insurance. Certificates of Insurance shall be prepared and executed by the insurance company or it's authorized agent, and shall contain provisions representing and warranting the following: The company is licensed and admitted to do business in the State of Texas, and is a subscriber to The Federal/State Guaranty Fund if applicable. The insurance's set forth by the insurance company are underwritten on forms, which have been Approved by the Texas State Board of Insurance. Sets forth all endorsements and insurance coverage's according to requirements



and instructions contained herein. Shall specifically set forth the notice of cancellation or termination provisions to Orange County.

### **Workers' Compensation Insurance**

#### **Purchase Order or Contract will NOT be released until vendor provides all required documents to Orange County Purchasing.**

1 Definitions:

1.1. **Certificate of coverage ("Certificate")** – A copy of a certificate of insurance, a certificate of authority to self-insure issued by the commission, or a coverage agreement, TWCC-81, TWCC-82, TWCC-83, or TWCC-84 showing statutory workers' compensation insurance coverage for the person's or entity's employees providing services on a project, for the duration of the project.

1.2. **Duration of the project** – Includes the time from the beginning of the work on the project until the contractor's/person's work on the project has been completed and accepted by the governmental entity.

1.3. **Persons providing services on the project ("subcontractor") in article 406.096** –

Includes all persons or entities performing all or part of the services under the contractor has undertaken to perform on the project, regardless of whether that person contracted directly with the contractor and regardless of whether that person has employees. This includes, without limitation, independent contractors, subcontractor, leasing companies, motor carriers, owner-operators, employees of any such entity, or employees of any entity which furnishes persons to provide services on the project. "Services" includes, without limitation, providing, hauling or delivering equipment or materials, or providing labor, transportation, or other service related to a project. "Services" does not include activities unrelated to the project, such as food/beverage vendors, office supply deliveries, and delivery of portable toilets.

2. The Contractor shall provide coverage, based on proper reporting of classification code and payroll amounts and filing any coverage agreements, which meets the statutory requirements of Texas Labor Code, Section 401.011(44) for all employees of the contractor providing services on the project, for the duration of the project.

3. The Contractor must provide a certificate of coverage to the governmental entity prior to being awarded the contract.

4. If the coverage period shown on the Contractor's current certificate of coverage ends during the duration of the project, the Contractor must, prior to the end of the coverage period, file a new certificate of coverage with the governmental entity showing that coverage has been extended.

5. The Contractor shall obtain from each person providing services on a project, and provide to the governmental entity:

5.1. A certificate of coverage, prior to that person beginning work on the project, so the governmental entity will have on file certificates of coverage showing coverage for all persons providing services on the project; and

5.2. No later than ten (10) days after receipt by the Contractor, a new certificate of coverage showing extension of coverage, if the coverage period shown on the current certificate ends during the duration of the project.

6. The Contractor shall retain all required certificates of coverage for the duration of the project and for one (1) year thereafter.

7. The Contractor shall notify the governmental entity in writing by certified mail or personal delivery, within ten (10) days after the contractor knew or should have known, of any change that materially affects the provision of coverage of any person providing services on the project.

8. The Contractor shall post on each project site a notice, in the text, form and manner prescribed by the Texas Workers' Compensation Commission, informing all persons providing services on the project that they are required to be covered, and stating how a person may verify coverage and report lack of coverage.
9. The Contractor shall contractually require each person with whom it contracts to provide services on a project to:
  - 9.1 Provide coverage, based on reporting of classification codes and payroll amounts and filing of any coverage agreements, which meets the statutory requirements of Texas Labor Code, Section 401.011(44) for all its employees providing services on the project, for the duration of the project.
  - 9.2. Provide to the Contractor, prior to that person beginning work on the project a certificate of coverage showing that coverage is being provided for all employees of the person providing services on the project, for the duration of the project.
  - 9.3. Provide the Contractor, prior to the end of coverage period, a new certificate of coverage showing extension of coverage, if the coverage period shown on the current certificate of coverage ends during the duration of the project.
  - 9.4. Obtain from each person with whom it contracts, and provide to the Contractor:
    - 9.4.1. A certificate of coverage, prior to the other person beginning work on the project; and
    - 9.4.2. The coverage period, if the coverage period shown on the current certificate of a new certificate of coverage showing extension of coverage, prior to the end of coverage ends during the duration of the project.
  - 9.5. Retain all required certificates of coverage on file for the duration of the project and for one (1) year thereafter.
  - 9.6. Notify the governmental entity in writing by certified mail or personal delivery, within ten (10) days after the person knew or should have known, of any change that materially affects the provision of coverage of any person providing services on the project; and
  - 9.7. Contractually require each person with whom it contracts to perform as required by paragraphs I.1. – I.7., with the certificates of coverage to be provided to the person for whom they are providing services.
10. By signing this contract or providing or causing to be provided a certificate of coverage, the Contractor is representing to the governmental entity that all employees of the contractor who will provide services of the project will be covered by workers' compensation coverage for the duration of the project, that the coverage will be based on proper reporting of classification codes and payroll amounts, and that all coverage agreements will be filed with the appropriate insurance carrier or, in the case of a self-insured, with the commission's Division of Self-Insurance Regulation. Providing false or misleading information may subject the contractor to administrative penalties, criminal penalties, civil penalties, or other civil actions.
11. The Contractor's failure to comply with any of these provisions is a breach of contract by the Contractor which entitles the governmental entity to declare the contract void if the Contractor does not remedy the breach within ten (10) days after receipt of notice of breach from the governmental entity.

## **BONDING REQUIREMENTS**

Orange County Texas will require bonds for any construction, repair or alteration of public works. **No purchase order will be released until vendor provides all required documents to Orange County Purchasing.**

The successful bidder shall be required, at his own expense, to furnish the Orange County Purchasing Agent within ten (10) days of notification of award with certified copies of all bond or bonds as per bid specifications. Failure to furnish bond or bonds will result in bid being declared non-responsive. Non-responsive bids will not be considered for award.

### **Minimum Bid Bonds**

**Bid bonds will not be required for contracts that are valued at less than \$25,000.00.**

Bid bonds will not be required from any bidder or proponent whose rates are subject to regulation by a state agency as per Texas Local Government Code 262.032 (d).

If the Purchasing Agent determines that a bid bond is required for a particular contract, the notice to bidders or request for proposals or offers will state that a bid bond in the amount of 5% of the contract price is required and that it must be executed by a surety company authorized to do business in Texas.

### **Bid Bond**

Orange County Texas will require bonds for construction, repair or alteration of public works. **A bid bond MUST be submitted with any bid or proposal over \$25,000.00. The bid bond shall be in the amount of 5% of the bid price and is to be issued by a surety company authorized to do business in Texas.**

Bid bonds will not be required from any bidder or proponent whose rates are subject to regulation by a state agency as per Texas Local Government Code 262.032 (d).

**No exceptions to bond request will be made. Failure to furnish bid bonds, performance bonds and/or payment bonds will result in bid being declared non-responsive. Non-responsive bids will not be considered for award.**

### **Performance Bond**

Orange County Texas will require performance bonds for construction, repair or alteration of public works. The successful bidder shall be required, at his own expense, to furnish the Orange County Purchasing Agent within ten (10) days of notification of award with certified copies of all bond or bonds as per bid specifications. Failure to furnish bond or bonds will result in bid being declared non-responsive.

**For all contracts in excess of \$50,000.00 for the construction, repair or alteration of a public work or the prosecution or completion of any public work, the contractor must execute a performance bond that:**

1. Is payable to the county,
2. Is in the full amount of the contract,
3. Is conditioned on faithful performance of the work in accordance with the plans, specifications, and contract documents,
4. Is solely for the protection of the county,
5. Executed by a corporate surety or sureties in accordance with the Insurance Code, and
6. Bond must remain in effect for one year beyond the date of acceptance by Owner.

Any performance bond that is furnished by a contractor in attempted compliance with the requirements of TEX. GOV'T CODE ANN., Ch. 2253 will be construed as in conformity with that chapter in relation to rights created, limitations on the bond and remedies provided. Bond must be executed by a corporate surety in accordance with Section 1, Chapter 87, Acts of 56<sup>th</sup> Legislature, Regular Session, 1959 (Article 7.19-1, Vernon's Texas Insurance Code)

**No exceptions to bond request will be made. Failure to furnish bid bonds, performance bonds and/or payment bonds will result in bid being declared non-responsive. Non-responsive bids will not be considered for award.**

**Payment Bond**

Orange County Texas will require payment bond for construction, repair of alteration of public works, If the Purchasing Agent determines that a payment bond is required for a particular contract, the notice to bidders or request for proposals or offers will state that a payment bond in the full amount of the contract price is required. Said payment bond must be executed by a company authorized to do business in Texas before the contractor commences work and within ten (10) days after the contract award is sent to the contractor. Payment bonds will not be required from any bidder or proponent whose rates are subject to regulation by a state agency as per Texas Local Government Code 262.032 (d). For all contracts in excess of \$25,000.00 for the construction, repair or alteration of a public work or the prosecution or completion of any public work, the contractor must execute a payment bond that:

Payment bond, must be issued by a State approved surety in accordance with Article 7.19-1 Bond of Surety Company; Chapter 7 of the Insurance Code, must also be for not less than one hundred percent (100%) of the contract price and remain in effect for one year beyond the date of acceptance by the Owner.

1. Is solely for the protection of all claimants supplying labor and material in the performance of work provided in the contract,
2. Is payable to the county for the use of these claimants,
3. Is in the full amount of the contract,
4. Executed by a corporate surety or sureties in accordance with the Insurance Code, and
5. Is in a form approved by the Commissioners' Court.

Payment bonds should be effective from commencement of performance until the end of the fourth month after all items of work, for the project are completed unless releases are obtained from all subcontractors and materials. Any payment bond that is furnished by a contractor in attempted compliance with the requirements of TEX. GOV'T CODE ANN., Ch. 2253 will be construed as in conformity with that chapter in relation to rights created, limitations on the bond and remedies provided. Bond must be executed by a Corporate surety in accordance with Section 1, Chapter 87, Acts of 56<sup>th</sup> Legislature, Regular Session, 1959 (Article 7.19-1, Vernon's Texas Insurance Code).

**No exceptions to bond request will be made. Failure to furnish bid bonds, performance bonds and/or payment bonds will result in bid being declared non-responsive. Non-responsive bids will not be considered for award.**

**BID BOND  
SAMPLE**

KNOW ALL MEN BY THESE PRESENTS, that we the undersigned, \_\_\_\_\_ as PRINCIPAL, and \_\_\_\_\_, as SURETY are held and firmly bound unto \_\_\_\_\_ hereinafter called the "Owner", in the penal sum of \_\_\_\_\_ Dollars, \$ \_\_\_\_\_, lawful money of the United States, for the payment of which sum well and truly to be made, we bind ourselves, our heirs, executors, administrators, successors, and assigns, jointly and severally, firmly by these presents.

THE CONDITION OF THIS OBLIGATION IS SUCH, that whereas the Principal has submitted the Accompanying Proposal, dated \_\_\_\_\_, for \_\_\_\_\_.

NOW, THEREFOR, if the Principal shall not withdraw said Proposal within the period specified therein after the opening of the same, or, if no period be specified, within thirty (30) days after the said opening, and shall within the period specified therefor, or if no period be specified, within ten (10) after the prescribed forms are presented to him for signature, enter into a written contract with the Owner in accordance with the Proposal as accepted, and give bond with good and sufficient surety or sureties, as may be required, for the faithful performance and proper fulfillment of such contract; or in the event of the withdrawal of said Proposal within the period specified, or the failure to enter into such Contract and give such bond within the time specified, if the Principal shall pay the Owner the difference between the amount specified in said Proposal and the amount for which the local Public Agency may procure the required work or supplies or both, if the latter be in excess of the former, then the above obligation shall be void and of no effect, otherwise to remain in full force and virtue.  
Seals this \_\_\_\_\_ day of \_\_\_\_\_, the name and corporate seal of each corporate party being hereto affixed and these present signed by its undersigned representative, pursuant to authority of its governing body.

By: \_\_\_\_\_

Affix  
Corporate  
Seal

By: \_\_\_\_\_

Affix  
Corporate  
Seal

By: \_\_\_\_\_

**PAYMENT BOND  
SAMPLE**

KNOW ALL MEN BY THESE PRESENTS: that

\_\_\_\_\_  
(Name of Contractor or Company)

\_\_\_\_\_  
(Address)

a \_\_\_\_\_, hereinafter called Principal,  
(Corporation / Partnership)

and \_\_\_\_\_  
(Name of Surety Company)

\_\_\_\_\_  
(Address)

Hereinafter called Surety, are held and firmly bound unto

\_\_\_\_\_  
(Name of Recipient)

\_\_\_\_\_  
(Recipient's Address)

Hereinafter called OWNER, in the penal sum of \$ \_\_\_\_\_

Dollars, \$ \_\_\_\_\_ in lawful money of the United States, for this payment of which sum well and truly to be made, we bind ourselves, successors, and assigns, jointly and severally, firmly by these presents.

THE CONFIDENTIALITY OF THIS OBLIGATION is such that whereas, the Principal entered into a certain contract with the OWNER, dated the \_\_\_\_\_ day of \_\_\_\_\_, a copy of which is hereto attached and made a part hereof for the construction of:

\_\_\_\_\_  
(Project Name)

NOW, THEREFORE, if the Principal shall promptly make payment to all persons, firms, SUB-CONTRACTORS, and corporations furnishing materials for or performing labor in the prosecution of the WORK provided for in such contract, and any authorized extension or modification thereof, including all amounts due for materials, lubricants, oil, gasoline, coal and coke, repairs on machinery, equipment and tools, consumed or used in connection with the construction of such WORK, and all insurance premiums on said WORK, and for all labor, performed in such WORK whether by SUB-CONTRACTOR or otherwise, then this obligation shall be void; otherwise to remain in full force and effect.

**PERFORMANCE BOND  
SAMPLE**

KNOW ALL MEN BY THESE PRESENTS: that

\_\_\_\_\_  
(Name of Contractor or Company)

\_\_\_\_\_  
(Address)

A \_\_\_\_\_ hereinafter called Principal, and

\_\_\_\_\_  
(Name of Surety Company)

\_\_\_\_\_  
(Address)

Hereinafter called Surety, are held and firmly bound unto

\_\_\_\_\_  
(Name of Recipient)

\_\_\_\_\_  
(Recipient's Address)

Hereinafter called OWNER, in the penal sum of \$\_\_\_\_\_ Dollars (\$\_\_\_\_\_) in lawful money of the United States, for the payment of which sum well and truly to be made we bind ourselves, successors, and assigns, jointly and severally, firmly in these presents.

THE CONDITION OF THIS OBLIGATION is such that whereas, the Principal entered into a certain contract with the OWNER dated the \_\_\_\_\_ day of \_\_\_\_\_, a copy of which is hereto attached and made a part hereof for the construction of:

\_\_\_\_\_  
\_\_\_\_\_  
\_\_\_\_\_

NOW THEREFORE, if the Principal shall well, truly and faithfully perform its duties in all the undertakings, covenants, terms, conditions, and agreements of said contract during the original term thereof, and any extensions thereof which may be granted by the OWNER, with or without notice to the Surety and during the one year guaranty period, and if he shall satisfy all claims and demands incurred under such contract, and shall fully indemnify and save harmless the OWNER from all costs and damages which it may suffer by reason of failure to do so, and shall reimburse and repay the OWNER all outlay and expense which the OWNER may incur in making good any default, then this obligation shall be void, otherwise to remain in full force and effect.



surety in accordance with Section 1, Chapter 87, Acts of 56<sup>th</sup> Legislature, Regular Session, 1959 (Article 7.19-1, Vernon's Texas Insurance Code).

**No exceptions to bond request will be made. Failure to furnish bid bonds, performance bonds and/or payment bonds will result in bid being declared non-responsive. Non-responsive bids will not be considered for award.**

RAYMOND GOULD COMMUNITY CENTER WALKING TRACK PROJECT 385  
CLAIBORNE STREET, VIDOR, TEXAS 77662

PROPOSAL NO: RFP-23006  
PRICING SHEET

---

**RECONSTRUCT THE WALKING TRACK:**

\$ \_\_\_\_\_

---

**PARKING BLOCKS:**

\$ \_\_\_\_\_

---

**UNDERGROUND STORM DRAINAGE:**

\$ \_\_\_\_\_

---

***Bidder Shall Return Completed Form with Offer***

**REFERENCE SHEET**

**RAYMOND GOULD COMMUNITY CENTER WALKING TRACK PROJECT 385  
CLAIBORNE STREET, VIDOR, TEXAS 77662**

**PROPOSAL NO:                      RFP-23006**

**LIST THREE (3) COMPANIES OR GOVERNMENTAL AGENCIES WHERE THESE  
ITEMS HAVE BEEN PROVIDED:**

**1.      COMPANY NAME:**

\_\_\_\_\_

**ADDRESS: \_\_\_\_\_ TELEPHONE NO. \_\_\_\_\_**

**CONTACT PERSON: \_\_\_\_\_ TITLE: \_\_\_\_\_**

**2.      COMPANY NAME:**

\_\_\_\_\_

**ADDRESS: \_\_\_\_\_ TELEPHONE NO. \_\_\_\_\_**

**CONTACT PERSON: \_\_\_\_\_ TITLE: \_\_\_\_\_**

**3.      COMPANY NAME:**

\_\_\_\_\_

**ADDRESS: \_\_\_\_\_ TELEPHONE NO. \_\_\_\_\_**

**CONTACT PERSON: \_\_\_\_\_ TITLE: \_\_\_\_\_**

***Bidder Shall Return Completed Form with Offer***

**OFFER AND ACCEPTANCE FORM**

**RAYMOND GOULD COMMUNITY CENTER WALKING TRACK PROJECT 385  
CLAIBORNE STREET, VIDOR, TEXAS 77662**

**PROPOSAL NO:                      RFP-23006**

To Orange County:

We hereby offer and agree to furnish the materials or service in compliance with all terms, conditions, specifications, and amendments in the Invitation for Bid and any written exceptions in the offer. We understand that the items in this Invitation for Bid, including, but not limited to, all required certificates are fully incorporated herein as a material and necessary part of the contract.

The undersigned hereby states, under penalty of perjury, that all information provided is true, accurate, and complete, and states that he/she has the authority to submit this Bid, which will result in a binding contract if accepted by Orange County.

We acknowledge receipt of the following amendment(s): \_\_\_\_\_, \_\_\_\_\_, \_\_\_\_\_, \_\_\_\_\_.

**I certify, under penalty of perjury, that I have the legal authorization to bind the firm hereunder:**

Company Name \_\_\_\_\_

Address Name \_\_\_\_\_  
City State Zip \_\_\_\_\_

Phone \_\_\_\_\_ Fax \_\_\_\_\_

E-mail \_\_\_\_\_ Printed Name \_\_\_\_\_

Signature of Person Authorized:

Signature \_\_\_\_\_

Printed Name \_\_\_\_\_

Title \_\_\_\_\_

Date \_\_\_\_\_

**Bidder Shall Return Completed Form with Offer**



**Orange County Purchasing Department**

714 Polk Street  
Orange, Texas 77630  
Phone (409) 882-7903  
Fax (409) 670-4170

April 18, 2023

To All Interested Vendors:

Due to recent legislative changes, in accordance with Vernon's Texas Codes Annotated, Local Government Code Title 5, Subtitle C, Chapter 171, all vendors who do business with a local government entity are required to complete a conflict of Interest questionnaire. We have attached the questionnaire to this letter and are asking that you complete the form where applicable, sign, date and return it with the attached Bid packet.

If you are not submitting a Bid, we still must have the questionnaire signed, dated and returned to us within thirty (30) days to ensure your ability to continue doing business with Orange County.

Thank you,  
Michelle Carroll  
Purchasing Agent  
Orange County Texas

# CONFLICT OF INTEREST QUESTIONNAIRE

For vendor or other person doing business with local governmental entity

Form CIQ

This questionnaire is being filed in accordance with chapter 176 of the Local Government Code by a person doing business with the governmental entity.

By law this questionnaire must be filed with the records administrator of the Local government not later than the 7<sup>th</sup> business day after the date the person becomes aware of facts that require the statement to be filed. See Section 176.006, Local Government Code.

A person commits an offense if the person violates Section 176.006, Local Government Code. An offense under this section is a Class C misdemeanor.

OFFICE USE ONLY

Date Received

1

Name of person doing business with local governmental entity.

2

**Check this box if you are filing an update to a previously filed questionnaire.**

(The law requires that you file an updated completed questionnaire with the appropriate filing authority not later than September 1 of the year for which an activity described in Section 176.006(a), Local Government Code, is pending and not later than the 7<sup>th</sup> business day after the date the originally filed questionnaire becomes incomplete or inaccurate.)

3

Name each employee or contractor of the local governmental entity who makes recommendations to a local government officer of the governmental entity with respect to expenditures of money AND describe the affiliation or business relationship.

4

Name each local government officer who appoints or employs local government officers of the governmental entity for which this questionnaire is filed AND describe the affiliation or business relationship.

**Bidder Shall Return Completed Form with Offer**

# CONFLICT OF INTEREST QUESTIONNAIRE

For vendor or other person doing business with local governmental entity

Form CIQ

Page 2

5

**Name of local government officer with whom filer has affiliation or business relationship. (Complete this section only if the answer to A, B, or C is YES.)**

This section, item 5 including subparts A, B, C & D must be completed for each officer with whom the filer has affiliation or other relationship. Attach additional pages to the Form CIQ as necessary.

A. Is the local government officer named in this section receiving or likely to receive taxable income from the filer of the questionnaire?

Yes

No

B. Is the filer of the questionnaire receiving or likely to receive taxable income from or at the direction of the local government officer named in this section AND the taxable income is not from the local governmental entity?

Yes

No

C. Is the filer of this questionnaire affiliated with a corporation or other business entity that the local government officer serves as an officer or director, or holds an ownership of 10 percent or more?

Yes

No

D. Describe each affiliation or business relationship.

6

\_\_\_\_\_  
Signature of person doing business with the governmental entity

\_\_\_\_\_  
Date

**Bidder Shall Return Completed Form with Offer**

**RESIDENCE CERTIFICATION**

Pursuant to Texas Government Code §2252.001 *et seq.*, as amended, Orange County requests Residence Certification. §2252.001 *et seq.* of the Government Code provides some restrictions on the awarding of governmental contracts; pertinent provisions of §2252.001 are stated below:

(3) "Nonresident Bidder" refers to a person who is not a resident.

(4) "Resident Bidder" refers to a person, whose principal place of business is in this state, including a contractor whose ultimate parent company or majority owner has its principal place of business in this state.

\_ I certify that \_\_\_\_\_ is a Resident Bidder of Texas as defined in \_\_\_\_\_ [Company Name] Government Code §2252.001.

\_ I certify that \_\_\_\_\_ is a Nonresident Bidder as defined in \_\_\_\_\_ [Company Name] Government Code §2252.001 and our principal place of business is \_\_\_\_\_ [City and State]

**Bidder Shall Return Completed Form with Offer**









SIDEWALK DRAIN  
RE: EXHIBIT "D"

PLACE 18 NEW WHEEL STOPS  
RE: EXHIBIT "C"

Raymond Gould Park

PROP. BY CONC. WALKING TRACK  
TOTAL LENGTH 1,270 FEET  
RE: EXHIBIT "B"

SIDEWALK DRAIN  
RE: EXHIBIT "D"

WALKING TRACK SITE PLAN  
EXHIBIT "A"

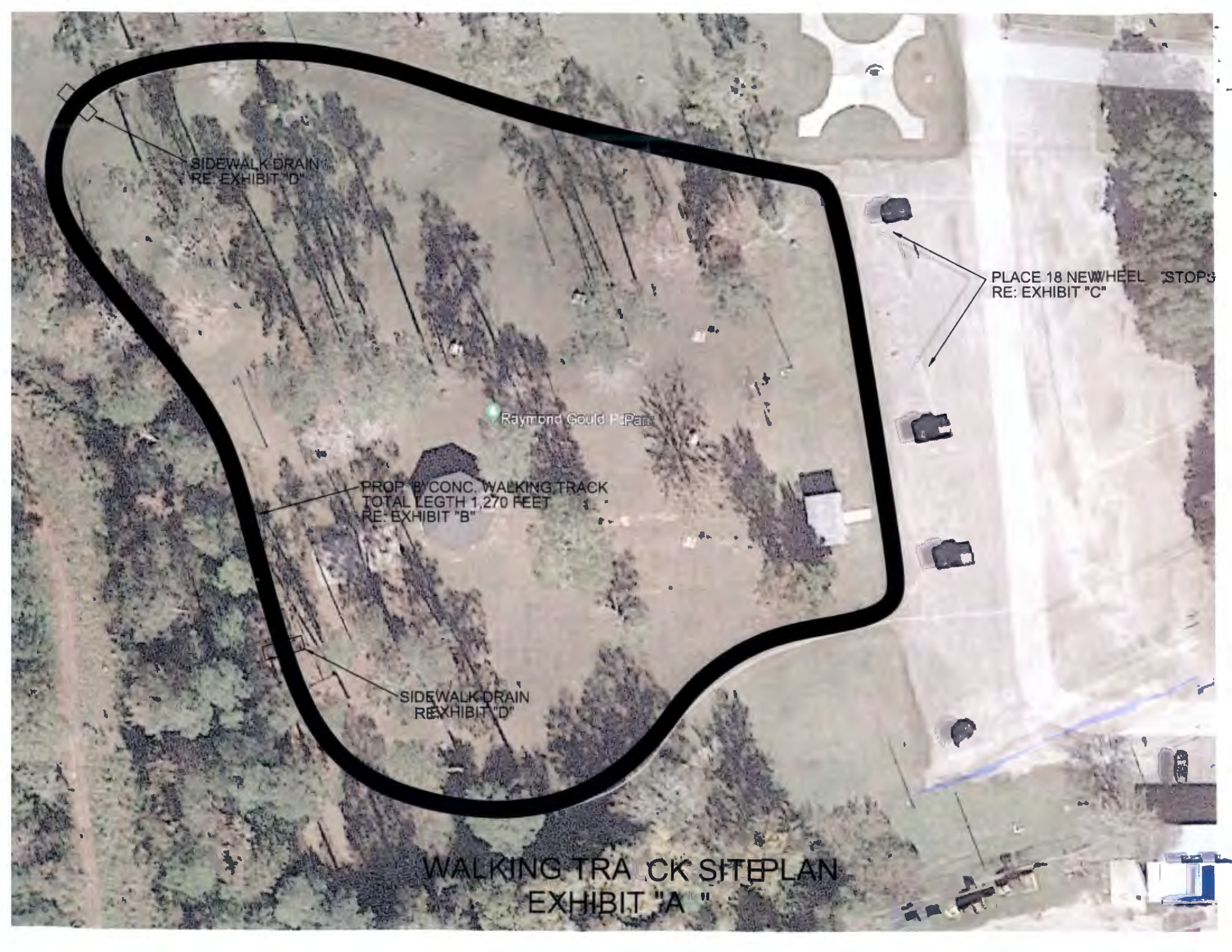

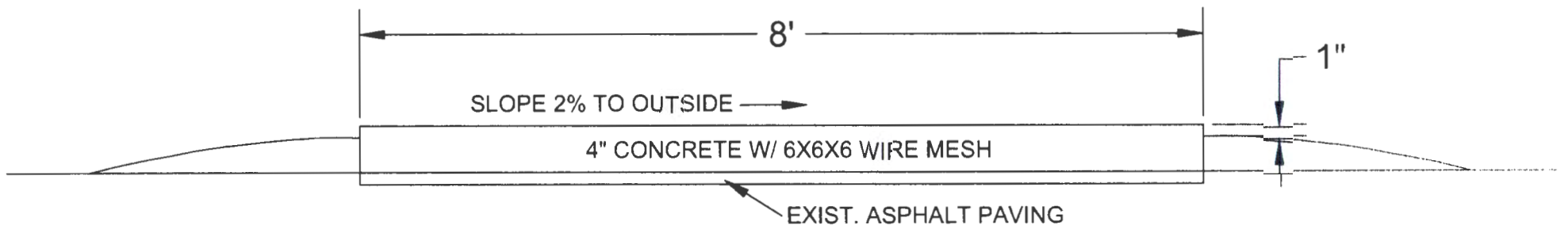
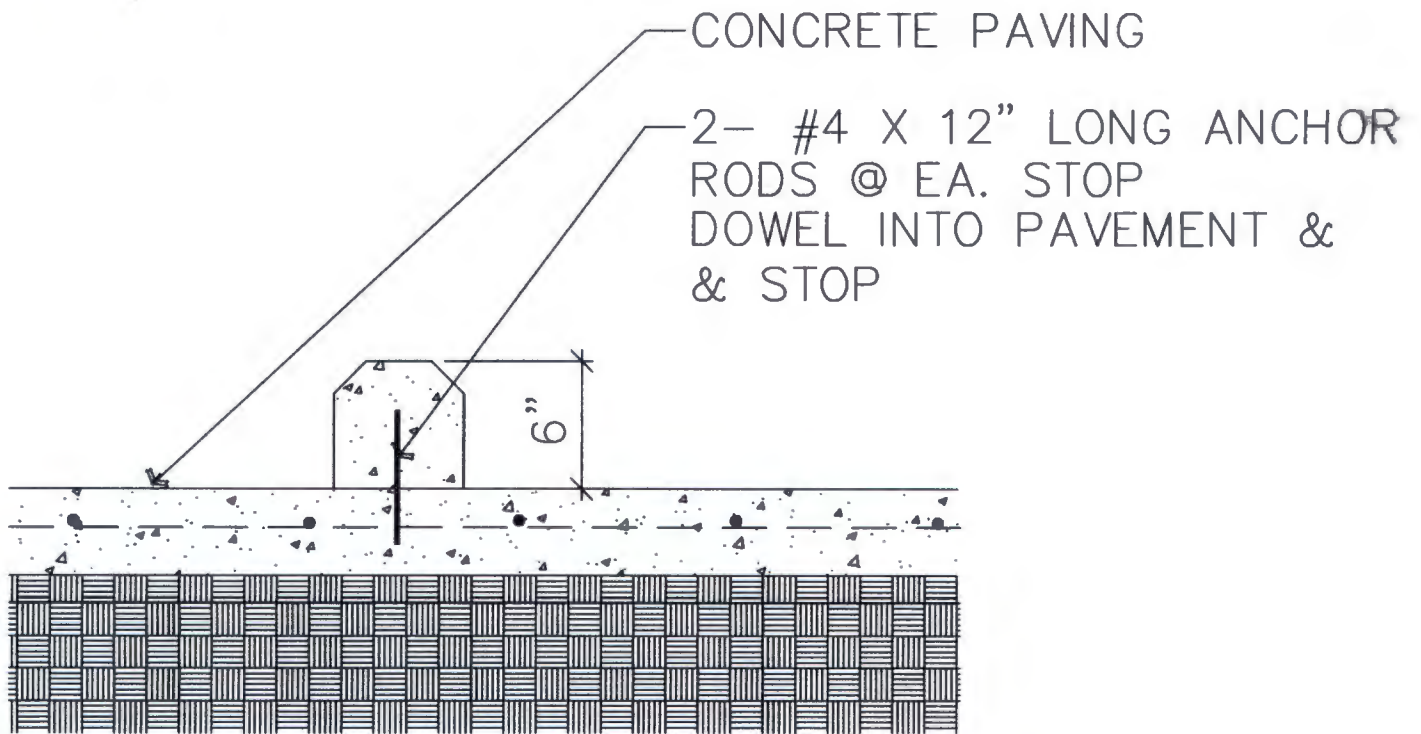
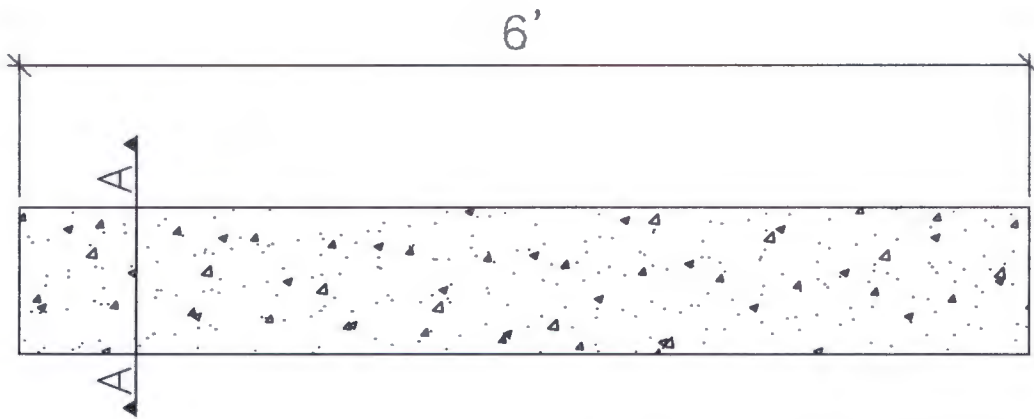

EXHIBIT "B"



SECTION A-A

CONCRETE: 3000PSI MIN.

MIN. WEIGHT: AT 6'-0" LENGTH - 190 LBS.

EXHIBIT "C" CONCRETE WHEEL STOP

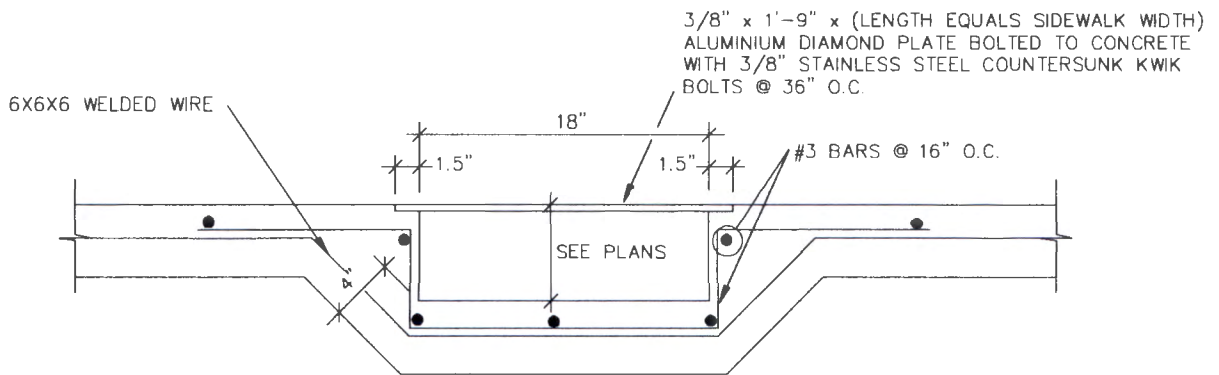
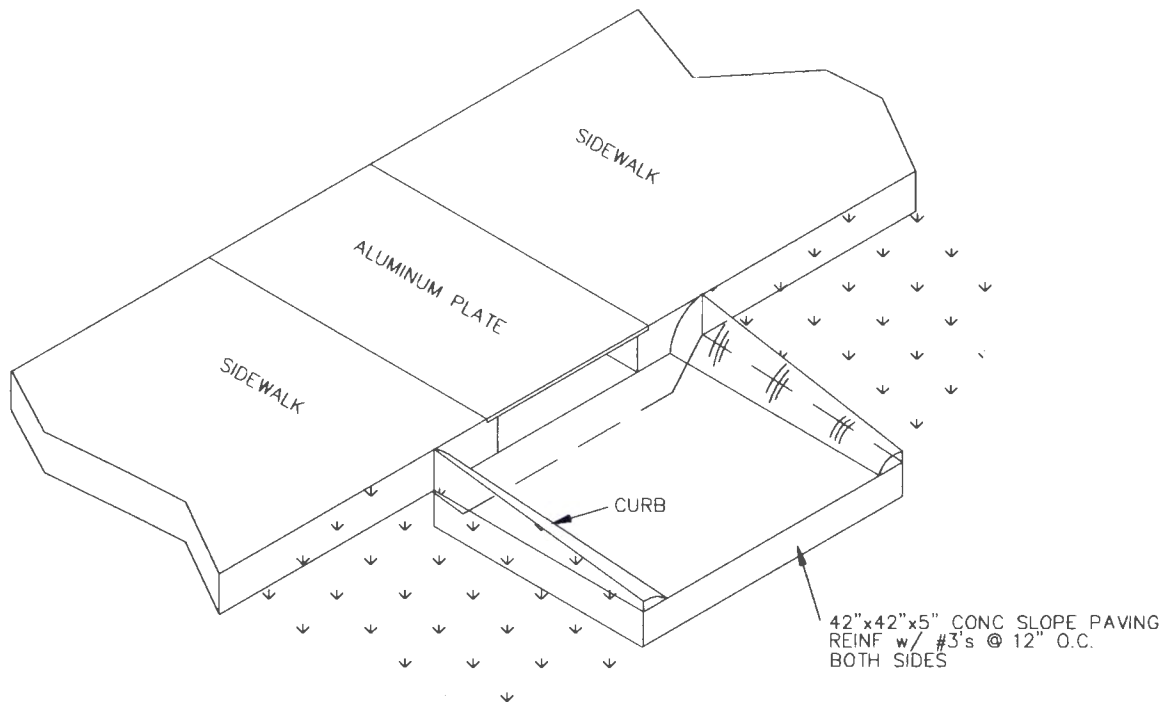

SIDEWALK DRAIN  
EXHIBIT "D"